

Features

Integrated PS1000_s Short style Paddle Shift units with Formula Paddles and 6 buttons w/12 position CommonCoder for a total of 30 independent inputs.

Real Structural 3K Carbon Fiber (or) Black G10 plates (*lc*).

Aluminum bezel buttons are included on the graphite version **ONLY**, the lower cost "*lc*" version includes plastic bezel buttons.

Fully engineered enclosed 3D printed housing for maximum rigidity.

Direct USB Interface w/ Coiled Dash length USB connection. (see options for extension)

70mm PCD mounting.

PSW_s 8mm Wheel Spacer is included for mounting to the Standard Accuforce Quick Release.

Options

To reach your computer the USB Cable from this wheel may need to be attached to an extension. The PSUSB_e is a dash mount style USB Extension for this purpose.



AF Formula Wheelbox

(PSPMOD_AF & PSMOD_AFic)

The PSMOD_AF is was designed specifically for use with the Accuforce Formula wheel and its unusual center spoke mounting. The PSMOD_AF allows for functionality beyond its visual capability through the use of Penguin r/c developed functionality. Direct inputs are provided through the main 4 wheel buttons and the secondary Micro buttons are used for CommonCoder control. The CommonCoder dial has 12 positions providing access to essentially 12 different Encoder settings which include labeled functions for the most commonly used adjustments.

Even though the PSPMOD_AF was designed with the Accuforce Formula Wheel in mind it will fit many other GT or Road style wheels of a diameter of 300mm and above. The short style PS1000_s Paddle Shift units and paddles are infinitely adjustable between an outer width of 200 - 260mm giving you the ability to fine tune the positioning of the paddles for your driving comfort.



PSMOD_AF & PSMOD_AF1c Instructions...

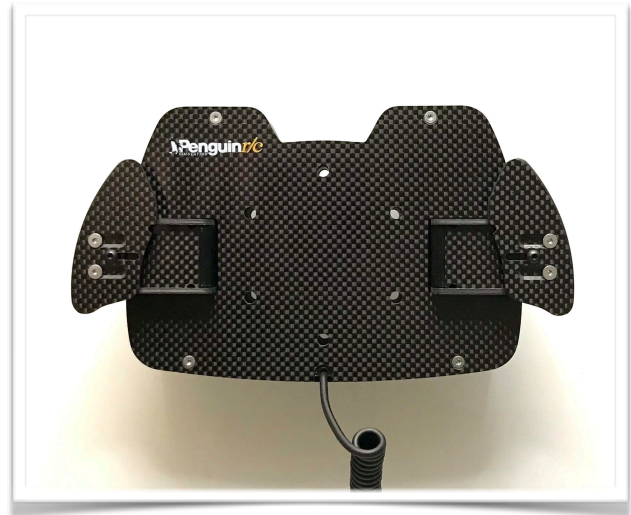

Connecting the PSMOD_AF and PSMOD_AF1c:

The PSMOD_AF is a full Windows HID device. Just plug the USB cable into your computer and Windows will locate and install the appropriate Game Ready HID Driver. Due to the length of the coiled cable you will probably want to use a USB extension cable (PSUSB_e) for USB connection that is mounted near your Wheelbase to allow the attached USB Cable full coil articulation during rotation.

Installing a Wheel & Mounting the MOD_ONE:

The PSMOD_AF wheel plate is designed mainly for use with the Accuforce Formula Wheel ([web link](#)). This wheel has an unusual center spoke section that is more in line with a larger diameter GT style wheel. This characteristic also allows the MOD_AF to be used with many smaller GT style wheels that have an open Horn Button area. When using a GT style wheel the buttons may be further away from the wheel diameter. If there are any concerns about a wheel fitting this box please feel free to email us and ask. Use the included or comparable M5 screws to mount the steering wheel to your 70mm PCD quick release or hub. The PSMOD_AF comes with the normally optional PSW_s spacer to allow for direct mounting to the standard Accuforce QR. If you are not using the Accuforce QR you can choose whether or not to use this spacer.

Using the CommonCoder System:

The two mini buttons at the top inside of the wheel marked "+" (black) and "-" (red) on the wheel are permanently linked to the CommonCoder selector dial. The use of these buttons changes depending on the position of the dial. The positions for the dial are labeled on the wheel with the most common adjustment types, however, each button pair may be assigned to any in game setting whether linked or not and settings include when the dial position is set to "OFF". This capability allows for 24 different functions through the use of the two buttons.

PSMOD_AF & PSMOD_AF1c Instructions

continued...

Paddle Adjustment:

The installed PS1000_s paddle shift units are fully width adjustable by 60mm total. Major adjustment can be made by moving the the Paddle switches to the any of the alternative mounting positions on the Paddle mounting platforms using the (4) T8 Torx screws. The paddles have infinitely adjustable slots to allow for precise setting for the remaining 10mm of travel, this final adjustment allows the paddles to be positioned at any width needed for your comfort. The PS1000_s Shift units have additional adjustments such as throw and optional tension changes. For further information on these additional adjustments please reference the Transmission Control Catalog.

Moving Paddle Shift Units:

Open the PSMOD_AF wheel box by removing the (4) T8 Torx screws around the outer edge of the box. This will allow you to remove the rear plate of the box. The strain relief for the USB cord should remain in place when removing the rear plate, however, if it should become dislodge it will need to be pressed back in place when re-installing the back plate.

Once the back plate is removed the Shift unit mounting positions will be accessible, you can move the paddle units on the platform bar by removing the (4) T8 screws and moving the paddle to a new position. (see fig 1) Each movement is 10mm in distance for a total of 30mm change that can be made on each side of the wheel. Only tighten the torque screws until snug and there is no play in the mounting plate, too much torque can result in stripping the plastic mount. Once done with one paddle do the same for the paddle on the other side. When moving the paddles to their outermost locations (20mm) we recommend installing the included Paddle Brace plates (figure 2) to limit the amount of flex due to leverage on the paddle mounts.

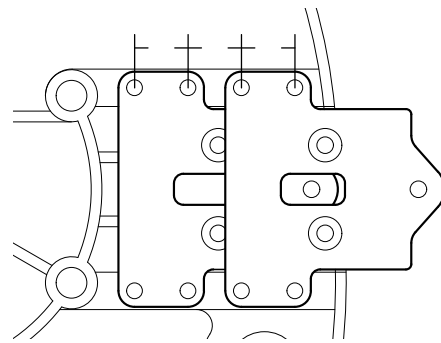

figure 1

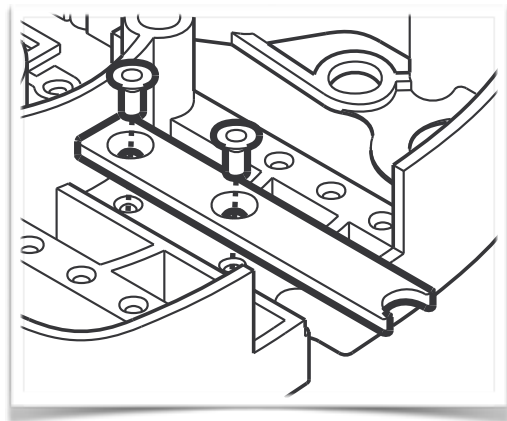

figure 2

Using Larger wheels with the PSMOD_AF and the PS1000_s:

The PS1000_s shift units are designed to have a shorter lever than the standard PS1000 shift units in order to work with smaller diameter wheels effectively. When using a larger wheel with this box that may need additional width to the paddle placement it is possible upgrade these units to the standard PS1000 by just replacing the lever installed on them.. If this is required for your purposes please feel free to contact us.

PSMOD_AF & PSMOD_AF1c Instructions

continued...

Recommended Button Assignments for iRacing :

Shift Units:

(-)	Upshift
(-)	Downshift
(+) & (-)	Exit Car

Buttons:

Yellow Button	Push to Talk
Green Button	Boost / Push to Pass
Red Button	Pit Limiter
Black Button	Select / OK



*SimXperience Formula
Accuforce (295mm)*

CommonCoder Dial Positions:

Symbol	Use
OFF	
BRK B	Traction Control
TC	Traction Control 2
TC2	Brake Bias
MAP	Fuel Map
ABS	Anti Lock Brake

Symbol	Use
F ARB	Anti-Roll Bar Front
R ARB	Anti-Roll Bar Rear
AUX	
BB +/-	Black Box - Increment
BB sel	Black Box - Select Item
BB pg	Black Box - Page Select

••• CommonCoder Dial stops at this location from factory (BB pg = last Right turn position / OFF = last Left turn position) - User may reposition knob.

Wheel Compatibility:

Compatible Wheels	Semi Compatible	Non Compatible
SimXperience Formula		Small Formula styles
SimXperience GT Wheels		Any Wheel w/o a Center Horn Opening
Most Standard Round/Semi-round		

(other wheels may be compatible (or not) please contact us and we will help determine if your wheel is compatible)



Instructions...

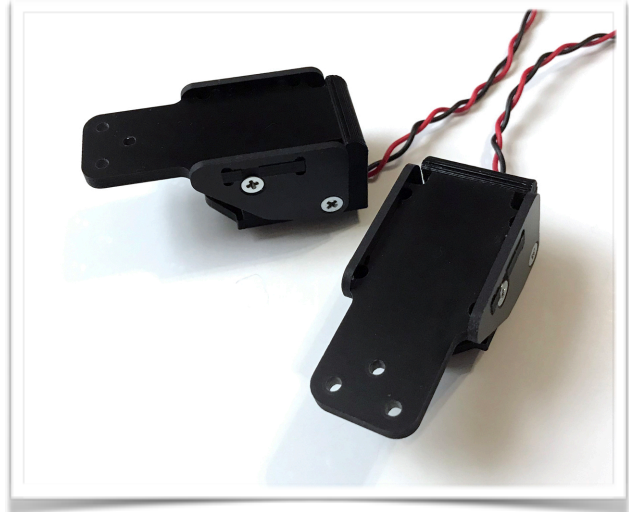
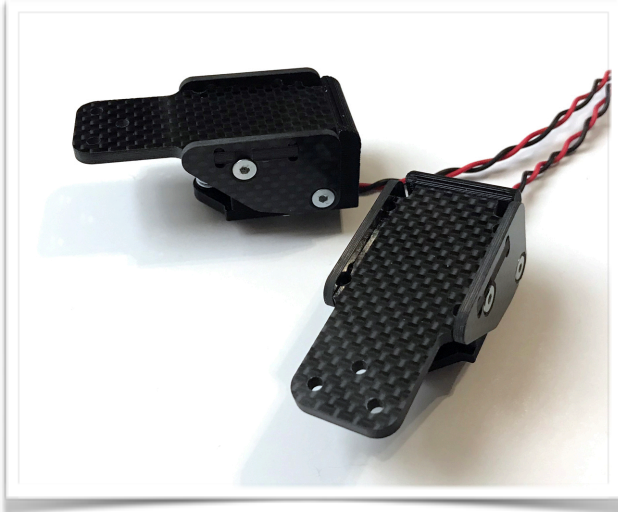

PS1000 (PS1000, PS1000lc)

Connecting the PS1000 Shift Units:

The PS1000 Shift units have two wires that need to be connected to your controller system allowing for a closed loop connection. You can use an existing button controller system (*adding to replacing an existing button or shift button*) or if you choose to develop one yourself. The electronics in the PS1000 are of a momentary normally open single pole design. Generally for most connections there is no polarity to the switch contacts though the wires included include both a red and black line. (*included wires are approx. 200mm in length*)

Mounting the PS1000 Shift Units:

Mounting of the PS1000 shift units is accomplished through the use of three screws in a triangulated pattern to help eliminate any wobble that may occur. The screw at the tip of the triangle that passes through the spring is also used for the travel limit of the paddle and does not need to be fully tightened to be effective. The remaining two screws are the main mounting screws and should be secured fully. The screws provided are of optimal lengths for attachment to a 3mm thick mounting plate. If a thicker mounting plate is used, longer M3.0 screws may be needed to secure the shift units and to reduce the paddle throw if desired. Replacement screw length should be extended by the approx. additional thickness of the mounting plate over 3mm. If you have issues finding appropriate screws for this purpose please contact us. (*templates and dimensions are on the technical specification pages*)

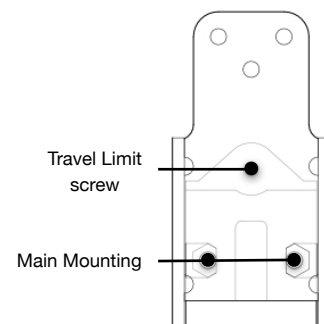

PS1000 (PS1000, PS1000lc)

continued...

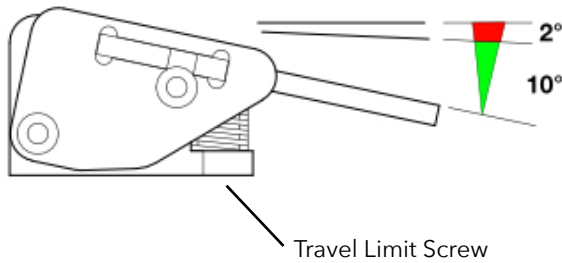

Travel Limit Length	Mounting plate thickness (mm)	Travel Limit Screw Length	MAX Degrees of travel* (approx)
18mm	x	18 + (x) =	2
17mm	x	17 + (x) =	4.5
16mm	x	16 + (x) =	7
15mm	x	15 + (x) =	9
14mm	x	14 + (x) =	11
13mm	x	13 + (x) =	FULL

(* when screw is fully seated to mounting plate *(not required)*)

Adjusting the PS1000 Shift Units:

The paddle lever throw for the PS1000 Shift units can be fully adjusted to preference by using the Travel Limit Screw. The PS1000 has a very fast actuation point that generally occurs within the first 2 degrees* of travel, setting the Travel Limit screw to a setting that does not allow this initial travel will stop the switch from activating. Any degree setting past that point is fully up to user preference up to a total of 12 degrees of travel. If you like a sharper feel to the actuation shorter travel is recommended. Longer travel will give a softer feel to the paddle as you will allow the paddle to move further before the paddle is stopped. The maximum travel limit screw length is 18mm + the thickness of the mounting plate for a fully seated screw (i.e. 18mm + 3mm material = 21mm travel limit screw used for 2 degrees of travel). The standard screw provided with the PS1000 Shift units is a 3x20mm flathead. This screw when fully seated in a 3mm mounting plate provides about 4.5 degrees of travel. It is NOT necessary to fully seat the Travel limit screw so finite adjustments can be made to the travel by just backing the screw out. If you need more travel and are unable to back the screw out you can get a shorter 3mm screw so that it can be fully seated but allow for more travel. The shortest recommended travel limit screw would be one that will hold the Spring Bushing in place when fully seated though a 13mm screw will allow full paddle travel.

(* 2 degrees is an approximate, some units may require a slightly shorter or longer throw for actuation, This will only be noticeable if you are trying to achieve the shortest actuation throw possible.

Notes:

Grinding tactile feel issue - Due to the travel limit screw being placed in the middle of the actuation spring, under certain circumstances the spring may rub the travel adjustment screw creating a grinding feel in the paddle during travel. This issue is easily corrected by turning the spring so it sits more perpendicular with the internal screw.

Installing PS1000 Tactile Options:

PS1003 - Preload and Limiter Kit - The PS1003 Preload and Limiter Kit provides additional adjustment to the PS1000 feel in that you can adjust the amount of force that is required to initially move the shift lever based on the spring installed in the PS1000. This is done by adding spacers underneath the spring positioning bushing, Each large aluminum spacer included in the kit is 1mm thick and you can add up to 4 of them before possibly running into issues with over compression of the spring. At the point of over compression it is best to move to a harder spring. Also included in the kit are additional 3mm limiting screws in different lengths and spacers to allow seating of the screw should you need a longer throw on the paddle but cannot adjust the included Travel Limit screw any further due to your particular mounting.

PS1000 (PS1000, PS1000lc)

Tactile Options continued...

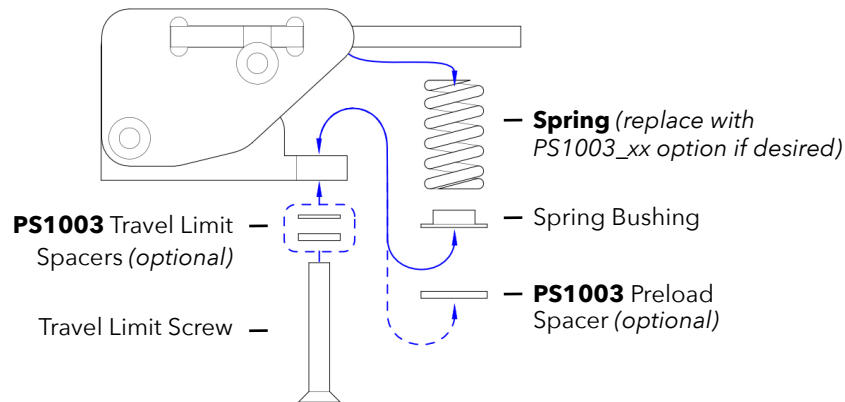

PS1003_s, _m, _h, and _eh - Spring Kits - The various P1003 spring kits allow you to adjust the overall feel of the paddles from soft to very hard. This adjustment is all about personal preference as everyone likes a different feel from their controls. We have selected the medium weight springs (*PS1003_m*) as the standard spring for the PS1000 since it provides a good weight to the shift action to give a solid positive feel without being super heavy. This spring is considerably heavier than that of most consumer level shift units that come standard with the wheels.

The Springs in the units can be changed by fully backing out the travel limit screw. This will allow the spring unit and positioning bushing to be removed from the shift unit by sliding the spring out from between the lever and inner structure. Be careful not to lose the positioning bushing as it is small and required to keep the spring from moving. Once the stock spring is removed you can replace the spring with one of the optional sets, the positioning bushing is placed on the bottom of the spring. Reinstall the travel limit screw to secure the spring in the correct location and reset your paddle travel.

Installing PS1000 Adaptive Options:

PS1004 - Spacer Kit - The PS1004 spacer plate is placed between the base of the PS1000 shift unit and the mounting plate used. This spacer moves the shift unit 3mm further from the wheel for each one used. The PS1000 comes with long enough 3mm Mounting screws to be able to stack (two) of these plates along with a 3mm mounting plate thickness. When using these spacer plates the travel limit screw will need to be changed to retain the same degree limit previously set. To calculate the difference add 3mm in overall length of your current Travel Limit Screw for each spacer used. If you have issues locating appropriate 3mm screws for this purpose please contact us.

PS1004_a - 10mm Mount Adaptor Kit - This Adaptor plate allows the PS1000 shift units to be mounted to 10mm inline mounting plates. These Adaptors move the PS1000 units 3mm further back from the mounting plate in order for the mounting conversion to occur. To use place the included nuts into the counterbored inline positions and mount the plate to the PS1000 as normal, then use the included screws to mount the unit to the Inline 10mm mounting.

Notes:

Using 10mm inline paddles - The PS1004_a adaptor set can be used to mount Paddle Shift Units from other manufacturers that use a 10mm inline mounting provision to products designed with the Penguin r/c triangulated mount. (*i.e. Wheel Boxes and Wheel Plates*) To use, install the provided nuts into the triangulated mounting in the PS1004_a and attach the 10mm mount paddle to the plate, finish by installing on your Penguin r/c product.

PS1002_xx

Installation...

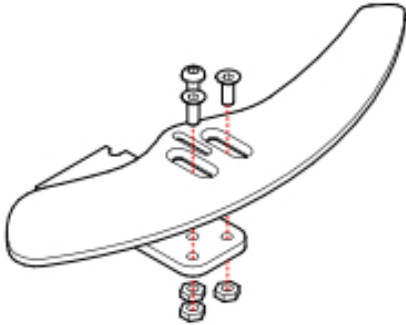

Figure 1: Paddle Mounting

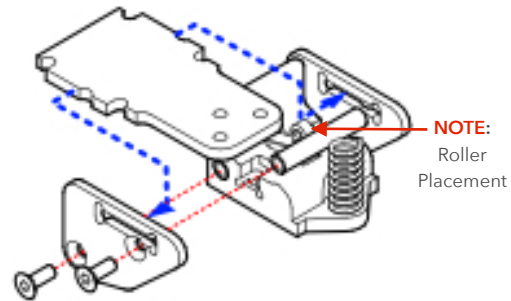

Figure 2: Lever Replacement & Lever Paddle Mounting

Mounting the PS1002 paddles (figure 1):

Most of the PS1002 Paddles are mounted with a fully adjustable triangulated mounting system. You can mount the paddles to the front or the back of the PS1000 levers depending on the distance needed for the paddles. We recommend mounting to the Back or Top of the lever so that the edge of the lever does not come in contact with your fingers during actuation. To mount the paddles place all three screws into the paddle with the two countersunk screws in the countersunk slot and the Button head screw in the center location. Loosely tighten the paddle to the lever with the included nuts, the paddle should slide with a little friction. Once you find the position you feel is optimal for the paddle tighten the center button head screw to lock in the location, then tighten each of the flat head screws to further secure the paddle in place. Once secure the paddle should not move or rotate on the mounting. It is recommended to tighten the center button head screw first as tightening the flat head screws prior to the button head can cause tracking which will alter the positioning of the paddle.

Notes:

Paddle Spacing - It is possible to space the paddle further away from the lever if wanted by using longer screws and spacers between the paddle and lever of the PS1000. Depending on the desired effect this could be a better Paddle spacing option than using the PS1004 spacer plates.

Mounting the PS1002_L paddles (figure 2):

The "L" Paddles provide a full lever replacement for the PS1000 Paddle shift units. These paddles give the most secure mounting but do not allow any width adjustment. To mount the "L" paddles you must disassemble a portion of the PS1000 switch unit. First remove the spring by removing the Travel Limit Screw. Disassemble the lever by removing the two retaining screws holding on one of the side plates. Once the side plate is loose you should be able to pull the side plate off and remove the standard lever. Replace the lever with the "L" paddle by slotting the paddle into the side plates and reinstalling the removed side plate. Complete the lever replacement by reinstalling the spring.

Notes:

CAUTION switch position information - When installing the Lever or "L" style paddle please be sure that the switch roller is located on the Top/Back of the front cross member and will come in direct contact with the lever plate. If it ends up under the cross member you may experience binding that can cause damage to the switch.



About, Contact, and Customs Information...

Contact Information

Address:

Penguin r/c
1230-P North Jefferson Street
Anaheim CA 92807

Website:

Main - www.penguinrc.com
Simulation Site - [click here...](#)

email:

simulation@penguinrc.com

Phone:

714.630.9015

Fax:

714.630.6250

Catalog Notes

Pricing - There are no prices in this catalog. Current pricing can be found on our website along with further information.

Ordering - Throughout this catalog there are "Visit our website..." links that will open up the ordering page for the items in this catalog.

Questions - Feel free to email us at any time.

About us...

Penguin r/c was opened in April of 1997 with the intent of creating the best products that could be made for reasonable prices. Originally we started business focusing on aftermarket parts and chassis upgrades for high performance remote control vehicles, pinpointing the areas where existing cars could be made to perform beyond their original design. Penguin r/c made a name for itself by achieving this goal through products where the additional performance gained far outweighed the cost of the parts. Having racked up a couple of championships and a good name in the market place we slowly transitioned into becoming a more involved OEM supplier for other manufactures in the r/c industry and other industries. We still sell and support our r/c products to this day and will continue to do so with every product we produce. In 2010 we started manufacturing parts for a high-end simulation company and found a renewed love for racing in the form of iRacing and Simulation equipment. In 2018 we decided that we could bring our expertise in manufacturing and design to the Simulation products market and started researching and designing what you see today. We hope to bring the same values and customer support to the simulation marketplace as we have for years as an OEM manufacturer and part supplier to the r/c industry.

Custom Designs...

Penguin r/c is capable of Custom Manufacturing and Design of prototype and production parts for individuals and companies. Most of our manufacturing is done in-house which allows us significant control over the quality and assembly of parts we manufacture and allows us to make prototypes that have the quality and durability of production pieces. If you have anything that you would like to produce please feel free to contact us about the possible product.

Our Warranty...

Penguin r/c offers a Limited Lifetime Warranty on all products we produce. This warranty includes full service (shipping included) for the first 90 days of original ownership. After that shipping to us is not included. Due to the openness of this warranty we may ask if you are capable of completing simple repairs yourself as we have found in many cases this can be beneficial to the user and us as it speeds any downtime associated with repair. Directed repairs such as this will not affect the overall warranty should something go wrong. This warranty covers all manufacturing defects or issues that are not related to normal wear and tear, abuse, or non Penguin r/c directed modifications or repair.